

Fans



Description

VL: centrifugal fan for direct assembly on circular duct

- galvanised steel casing
- motor with external rotor
- thermal protection
- IP 44 motors
- IP 55 terminal box
- operating temperature -40°C / +40°C

Including bracket

Accessories

REM 600: single-phase speed regulator

VL

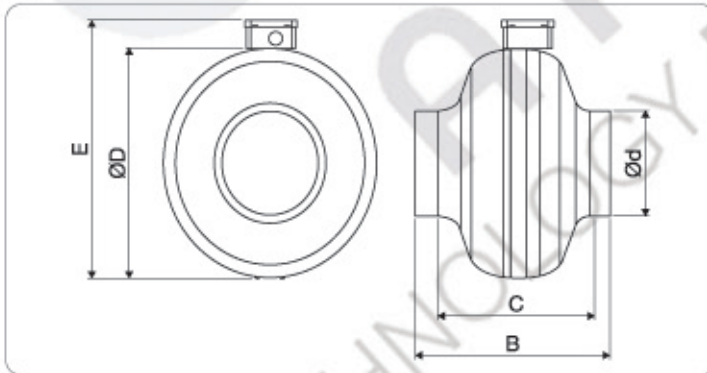

Selection table

Type	GR	Static pressure (Pa)				
		50	100	150	200	250
		Flow rate (m³/h)				
VL	100	325	260	220	170	100
VL	125	360	290	220	160	90
VL	160	790	700	600	500	420
VL	200	950	870	810	750	650
VL	250	950	850	790	700	620
VL	315	1400	1330	1250	1200	1150

Dimensions

Mod.	Watt	LWA dB(A)	Amp.	B	C	ØD	Ød	E	Kg
VL 100	74	71	0.31	189	152	244	100	287	3
VL 125	74	68	0.31	182	143	243	125	286	3
VL 160	100	75	0.50	217	166	344	160	387	4
VL 200	140	74	0.60	231	179	344	200	387	4.7
VL 250	140	75	0.60	230	167	344	250	387	7.7
VL 315	280	74	1.20	256	188	402	315	444	6