

ES



## Description

**ES:** steam humidifiers operating with the principle of the electrodes immersed in not-demineralised water  
 • production from 2 to 48 kg/h.

## Construction features

- structure in AISI stainless steel and polypropylene
- ON-OFF operation, proportional 0-10V and with integrated humidistat for humidity probe (4..20 mA same device)
- electronic microprocessor control that can be interfaced with DDC
- display for reading and programming work data
- level probe
- draining during stand-by
- water fill solenoid valve
- water drain pump with pre-set automatic functions to increase the life of the machine
- non-toxic polypropylene cylinder with stainless steel electrodes (easily to replace)
- possibility of re-calibrating steam production up to 20%
- operating test on each single machine

## Conformity

The product complies with the following directives and standards: 72/23 and 89/336 EEC EN 50081-1, 50082-1, 60335-1

## Accessories

**L250/L1000:** steam distributor with L = 250 / 1000 mm with DN 25 or 40 mm made of AISI 304/316 stainless steel with automatic condensate return

**TV:** steam pipe DN 25 – DN 40

**CL...:** spare cylinder complete with electrodes

- the following spare parts are also available at our service centre:
  - pumps
  - valves
  - electronic boards, etc.

## Description of components

### Key:

- |  |   |
|--|---|
| 1. Digital controller display          | 6. 3/4 gas filling solenoid valve           |
| 2. Steam production electrode cylinder | 7. Discharge pump                           |
| 3. Electrode cylinder O-ring           | 8. Siphon pipes                             |
| 4. Solenoid valve filling pipe         | 9. Tam electronic unit                      |
| 5. Pump discharge pipe                 | 10. Slim TLD microprocessor electronic unit |

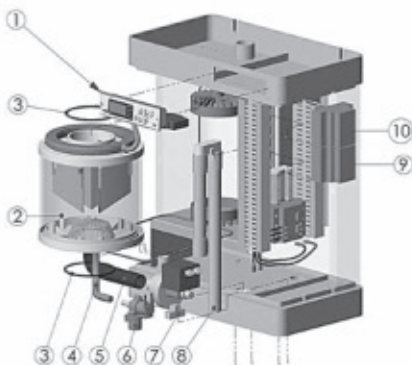

## Accessories

L 250		L 1000		TV		CL		
25	40	25	40	25	40	6	12	24
205	216	264	324	43/m	66/m	171	180	198

## Features

	ES6	ES12	ES24	ES48
Steam production (kg/h)	6.00	12.00	24.00	48.00
Electric power supply	400V 3/N 50-60 Hz			
Power (KW)	4.5	9	18	35
Absorbed current (A)	6.5	13	26	51
DN steam outlet mm	25	25	40	40
No. cylinders	1	1	1	2
Operating weight (kg)	13	18	37	74
Dimensions	Height (mm)	526	626	711
	Width (mm)	430	430	430
	Depth (mm)	240	240	240
Supply pressure	1-10 bar			

## Standard equipment for assembly and use

The humidifiers of the ES line for assembly and use are fitted with:

- 1 x 3/4 gas connections for water filling.
- 1 x 40-mm external diameter connection for draining water with fastening band.
- 1 x 25-mm external diameter connection for the steam pipe for models ES6 and ES12 and 40-mm external diameter for models ES25 and ES48 with relevant fastening band.
- 1 x user manual.
- 1 x final test checklist.



Use steam pipe only with the diameter indicated for the model, fasten it to the steam pipe with a clamp avoiding kinks (fig.8) and siphon bends that can generate dangerous pockets of condensate (fig.9!)

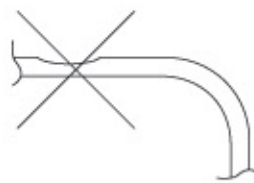

fig. 8

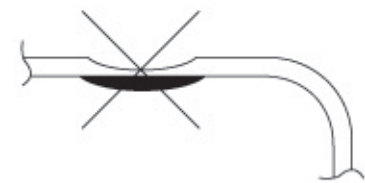

fig. 9